

ENERGIZER NO. L91

AA

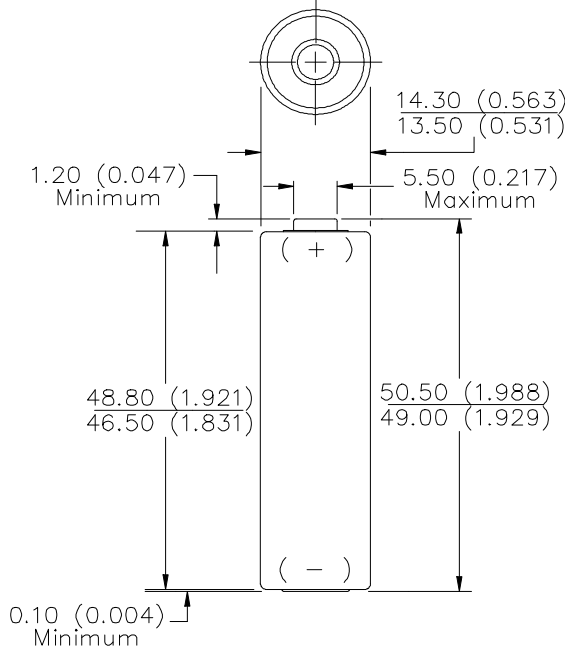

Industry Standard Dimensions in mm (inches)



- Chemical System:** Lithium
Lithium/Iron Disulfide (Li/FeS₂)
- Designation:** ANSI / NEDA 15LF
- Battery Voltage:** 1.5 Volts
- Average Weight:** 14.5 grams (0.5 oz.)
- Volume:** 8.0 cubic centimeters (0.5 cubic inch)
- Storage Temp:** -40°C to 60°C (-40°F to 140°F)
- Operating Temp:** -40°C to 60°C (-40°F to 140°F)
- Average Capacity:** 2900 mAh (to 1.0 volts)
(Rated capacity at 200 mA drain.)
- Max Discharge:** 2.0A Continuous
- Lithium Content:** Less than 1 gram (0.04 oz.) per cell
- Jacket:** Non-magnetic Plastic Label
- Transportation:** Meets requirements of 49CFR 173.185 (b) and IATA special provisions A45.
- Shelf Life:** 10 years (+)

CONSTANT CURRENT DISCHARGE
Typical Service

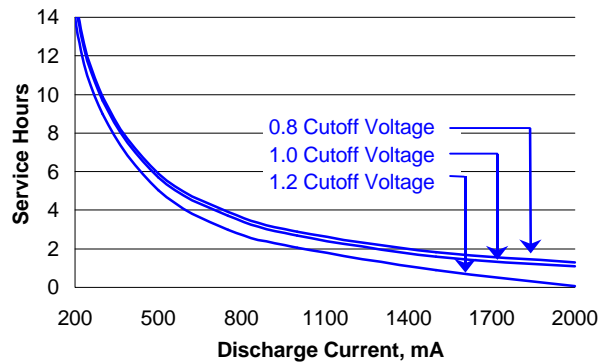

CONSTANT POWER DISCHARGE
Continuous @ 20°C to 0.9 volts

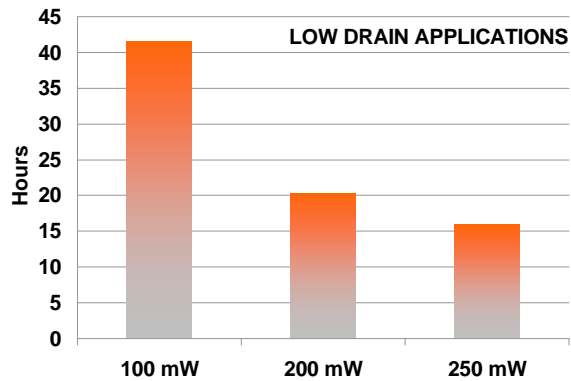

CONSTANT POWER DISCHARGE
Continuous @ 20°C to 1.0 volts

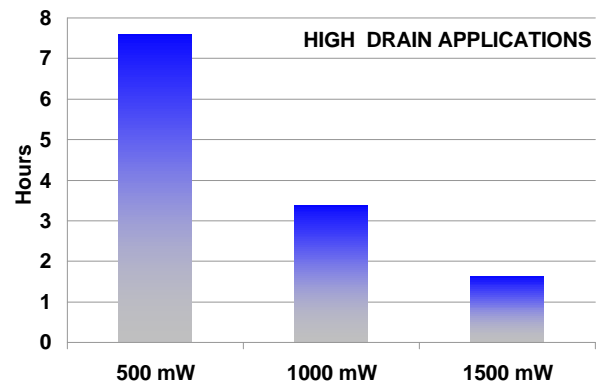

Important Notice

This data sheet contains information specific to batteries manufactured at the time of its publication.

Contents herein do not constitute a warranty.

Copyright © Eveready Battery Co. Inc. - All Rights Reserved

ENERGIZER NO. L91

Temperature Effects

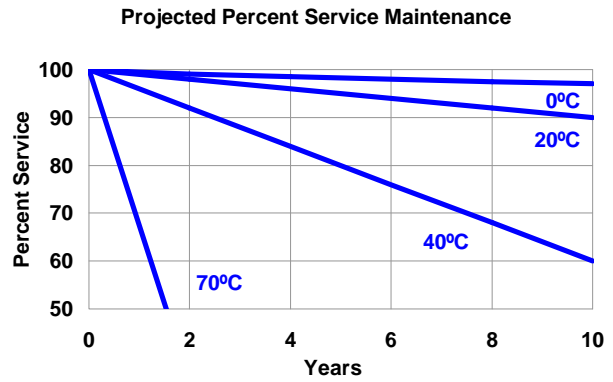
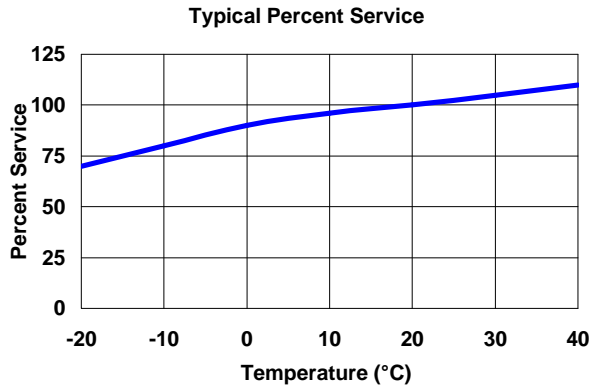

ANSI - IEC Industry Standard Tests @ 20° C

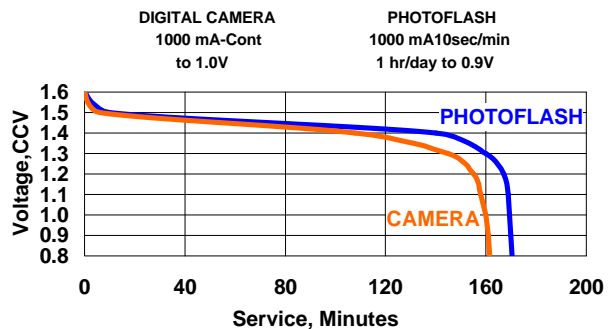
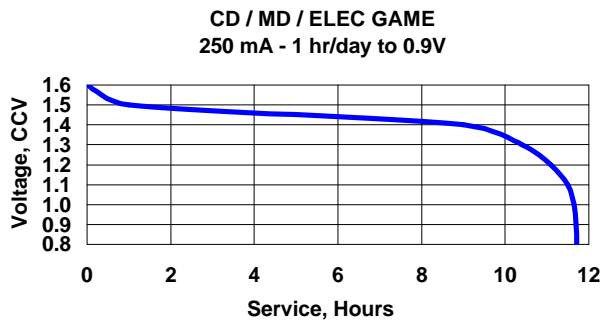
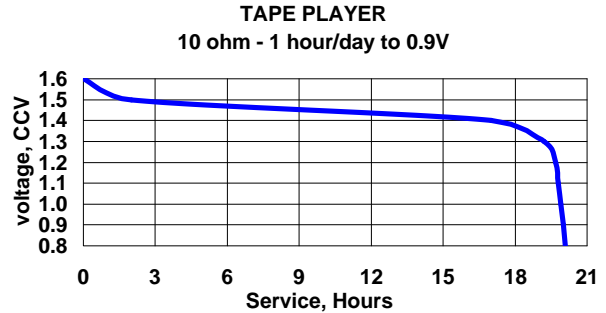
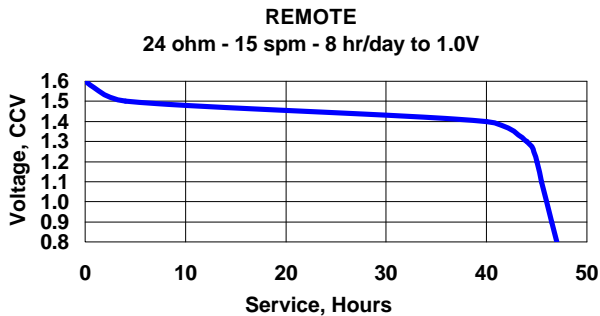
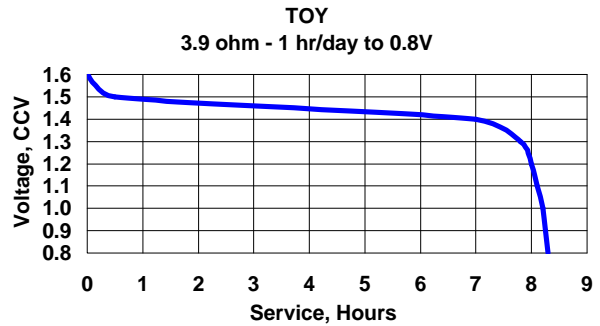
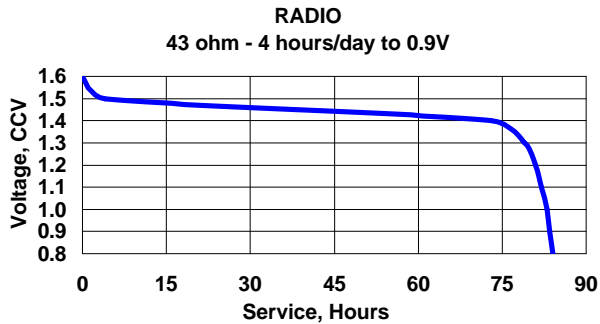

Important Notice

This data sheet contains information specific to batteries manufactured at the time of its publication.

Contents herein do not constitute a warranty.

Copyright © Eveready Battery Co. Inc. - All Rights Reserved